

Victorian EDA / TPI War Veteran Travel Pass

Information and Application form

The information included in this form is intended to assist the applicant in understanding if they are eligible for the Victorian Extreme Disablement Adjustment (EDA) / Totally Permanently Incapacitated (TPI) War Veteran Travel Pass.

The following is included in this form:

- EDA / TPI War Veteran Travel Pass information
- EDA / TPI War Veteran Travel Pass application form.

Who is eligible for the EDA / TPI War Veteran Travel Pass?

The Victorian EDA / TPI War Veteran Travel Pass is for veterans:

- Who are holders of a Department of Veterans Affairs (DVA) Gold Repatriation Health card embossed with EDA (Extreme Disablement Adjustment) or TPI (Totally Permanently Incapacitated) AND
- Who have undertaken war / peacekeeping / peacemaking service overseas (see page 3 for approved overseas war service) AND
- Who reside in Victoria.

What is the EDA / TPI War Veteran Travel Pass?

The EDA / TPI War Veteran Travel Pass is a free travel pass for veterans who have DVA Gold Repatriation Health Card embossed with EDA or TPI who have undertaken war/ peacemaking/peacekeeping service overseas, for use on the Victorian public transport network.

Who administers the EDA / TPI War Veteran Travel Pass?

The Metlink Central Pass Office is responsible for issuing Victoria's public transport free travel passes, including the EDA / TPI War Veteran Travel Pass.

How does the EDA / TPI War Veteran Travel Pass work?

The EDA / TPI War Veteran Travel Pass is a free registered myki with the pass holder's photograph and name printed on the card. The pass holder is required to carry the EDA / TPI War Veteran Travel Pass with them at all times while travelling on Victoria's public transport network.

EDA / TPI War Veteran Travel Pass holders need to touch on at the beginning and touch off at the end of each journey.

Where can I use the EDA / TPI War Veteran Travel Pass?

The EDA / TPI War Veteran Travel Pass entitles the pass holder to free travel on:

- Metropolitan trains, trams and buses
- V/Line services
- urban bus services in regional cities
- regional services that have a contract or service agreement with the Department of Transport.

Free travel passes do not necessarily apply to CountryLink, Great Southern Railway, airport services, tourist railways, privately run bus services and chartered trains, trams and buses. Please check with the relevant operator before booking or travelling.

What is classified as approved overseas war service?

Documentary evidence of overseas war service from one of the following theatres of war:

- World War 2 03/09/1939 – 28/04/1952
- Korea 27/06/1950 – 19/04/1956
- Malaya 29/06/1950 – 30/09/1967
- Vietnam 31/07/1962 – 29/04/1975.

Or

ADF/Peacemakers: Association Papers as documentary evidence of related conflicts (but are not limited to):

- Afghanistan (War on Terror and UNMCTT)
- Africa (Sierra Leone, Namibia, Somalia, Rwanda, etc.)
- Cambodia
- East Timor
- Gulf War 1 & 2
- Iraq.

How do I apply for the EDA / TPI War Veteran Travel Pass?

This application form must be completed by the applicant or where the applicant is unable to complete and/or sign the form, by their guardian or agent.

The completed application form is submitted to the Metlink Central Pass Office for processing.

All applications are reviewed by the Metlink Central Pass Office for eligibility.

Where eligibility is unclear, the Metlink Central Pass Office may ask for more information from the applicant and/or the Department of Veteran Affairs.

How much does the EDA / TPI War Veteran Travel Pass cost?

The EDA / TPI War Veteran Travel Pass is free.

How do we obtain a replacement card?

The pass holder must advise the Metlink Central Pass Office as soon as possible if the Travel Pass is lost, stolen, non-operational or damaged, including if they become aware that the name or photograph is illegible. A free replacement Travel Pass will be issued.

Please note:

- A Statutory Declaration must be completed and submitted to the Metlink Central Pass Office for all lost or stolen travel passes.

EDA / TPI War Veteran Travel Pass Application form

How to apply

Step 1

Before completing the application form, the applicant must read and understand the information contained in this document.

Step 2

Applicant/Guardian/Agent to complete this application form.

Step 3

Obtain one (recent within three months) high quality, colour, passport-size photograph (from a passport photo outlet).

Get the reverse of the photograph signed by a Justice of the Peace. A list of people who can sign statutory declarations is available at www.justice.vic.gov.au/justices

Step 4

Applicants/Guardians/Agents need to read Section 5 Terms of use and Section 6: Privacy notice.

Step 5

Return this application form to:

Metlink Central Pass Office

At Southern Cross Station located between Bourke and Little Bourke streets near the bus interchanges.

or mail to

Metlink Central Pass Office

Southern Cross Station

Mail Box 58

99 Spencer Street

Docklands VIC 3008

Please note:

- Original applications and photographs cannot be returned under any circumstances.
- Incomplete applications, including those without signatures or signed photographs, cannot be processed.
- If successful, the applicant will receive the myki free travel pass within 10 business days.

How to complete this form

Applicants

- All applicants are required to complete sections 1 and 2.
- All applicants are required to attach the signed passport size photograph – Section 3.
- All applicants need to provide a colour photocopy of the DVA Gold Repatriation Health Card either embossed with EDA (Extreme Disablement Adjustment) or TPI (Totally and Permanently Incapacitated).
- All applicants will need to attach documentary evidence of war/peacemaking/peacekeeping overseas service.

Guardian / Agents

- If you are completing and signing this application form on behalf of the applicant you are required to complete sections 1, 2 and 3.

Please complete this application form in BLOCK LETTERS using blue or black pen.

Section 1: Applicant's details

The **EDA / TPI War Veteran Travel Pass** will only be issued to the person whose details appear below. One application must be completed per applicant.

Title: (please tick) Mr Mrs Miss Ms

Surname or family name: _____

First or given name: _____

Date of birth: ____ / ____ / ____ Male Female

Residential Address: _____

Suburb: _____

State: _____ Postcode: _____

Postal Address: _____

Suburb: _____

State: _____ Postcode: _____

Telephone – home: _____

Telephone – mobile: _____

Email (if available): _____

DVA file number: _____

Disability type: _____

Location of overseas war service: _____

Section 2: Applicant declaration

I confirm that the signature below verifies the following:

- I declare that the information in this application is correct.
- I have attached a colour photocopy of my DVA Gold Repatriation Health Card embossed EDA or TPI card.
- I have attached documentary evidence of my overseas war service.
- I accept the EDA / TPI War Veteran Travel Pass terms of use – Section 4.
- I have read the EDA / TPI War Veteran Travel Pass Travel Pass privacy notice- Section 5.
- I authorise that these details may be verified with the Department of Veterans' Affairs.

Applicant Signature:

OR

Date: ____ / ____ / ____

Guardian/Agent Signature for applicants unable to sign

Guardian / Agent Details

Guardian / Agent name (and relationship to the applicant)

Guardian / Agent telephone number: _____

Section 3: Photograph

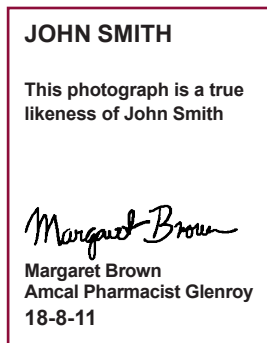

(Example on reverse side)

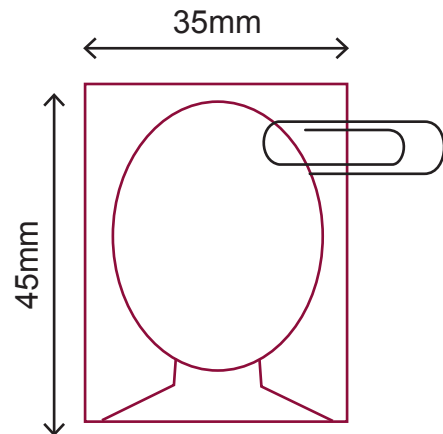

(Passport-size photograph)

A photograph is MANDATORY for ALL applicants.

Affix one recent (within three months) high quality, colour, passport-size photograph to the form.

The colour, passport size photograph:

- must be a clear head shot taken front on
- must have your full name printed on the reverse and signed by a Justice of the Peace certifying it is a true likeness of you (see example above).

Please note:

- A list of people who can sign statutory declarations can be found at www.justice.vic.gov.au/justices
- Photocopies of photographs or black and white photographs will not be accepted.
- The photograph is kept on file to make it easier for you to get a replacement EDA / TPI War Veteran Travel Pass in the event it is lost, stolen, becomes defective or damaged.

Section 4: Terms of use

1. The Travel Pass entitles the pass holder to free travel on Victoria's public transport network. As at the date of issue of these terms of use, this means:
 - metropolitan trains, trams and buses
 - V/Line services
 - urban bus services in regional cities
 - regional services that have a contract or service agreement with the Department of Transport.

Free travel passes do not necessarily apply to CountryLink, Great Southern Railway, airport services, tourist railways, privately run bus services and chartered trains, trams and buses. Please check with the relevant operator before booking or travelling.

2. The pass holder will be issued with a registered myki with their photograph and name printed on the card.
3. Only the person whose photograph and details appear on the Travel Pass is permitted to use the pass.
4. The pass holder must carry their Travel Pass at all times when travelling on Victoria's public transport network.
5. The Travel Pass remains the property of the Transport Ticketing Authority (TTA). Representatives of public transport authorities[#] may inspect, deactivate, suspend, hotlist or take possession of the Travel Pass or require its return at any time if the pass holder is in breach of the terms of use.
6. TTA may change these terms of use from time to time. The current version of the terms of use may be obtained by calling the Metlink Central Pass Office on **9619 1159**. Where TTA reasonably considers that any such change will have more than a minor detrimental effect on travel pass holders generally, the change will be notified by the Metlink Central Pass Office to pass holders in advance in writing.

7. The pass holder must not alter, tamper or interfere with the Travel Pass.
8. The pass holder agrees to advise the Metlink Central Pass Office as soon as possible if the Travel Pass is lost, stolen, damaged or non-operational, including if they become aware that the name or photograph is illegible.
9. A free replacement Travel Pass will be issued for all lost, stolen, damaged and non-operational Travel Passes.

Please note:

- A Statutory Declaration must be completed and submitted to the Metlink Central Pass Office for all lost or stolen Travel Passes.

Section 5: Privacy notice

You will generally be able to access your personal information. If personal information requested by the Transport Ticketing Authority (TTA) is not provided, TTA may not be able to provide the myki. For more information about privacy and on rights of access to personal information, visit myki.com.au or call **13 6954 (13 myki)**.

Personal information provided by or about you or generated by using your myki is collected by public transport authorities[#] to issue and administer the myki and relevant entitlements. Personal information held by public transport authorities[#] may be used or disclosed (including to each other) for the operation of myki, for ticketing enforcement, in emergencies, otherwise as required by or under law, or with your consent. Public transport authorities[#] may send you information about transport-related services.

[#] Public transport authorities means TTA, the Department of Transport and any agent, contractor or delegate of TTA and the Department of Transport including Metlink and public transport operators.

Section 6: Contacts for further information

For all EDA / TPI War Veteran Travel Pass enquires you can contact the following services for assistance:

Metlink Central Pass Office

Telephone: (03) 9619 1159

Visit Staff: At Southern Cross Station located between Bourke and Little Bourke streets near the bus interchanges

Website: www.metlinkmelbourne.com.au

TTY: (03) 9619 2727

National Relay Service: 13 36 77

Speech-to-Speech Relay Service: 1300 555 727

Multilingual information

For all EDA / TPI War Veteran Travel Pass telephone enquiries in languages other than English, please use the following phone numbers:

Arabic	9321 5440	Mandarin	9321 5454
Cantonese	9321 5441	Somali	9321 5446
Croatian	9321 5442	Spanish	9321 5447
Dinka	9321 5452	Sudanese	9321 5453
Greek	9321 5443	Turkish	9321 5448
Italian	9321 5444	Vietnamese	9321 5449
Macedonian	9321 5445		

All other foreign languages 9321 5450