

Scooter and Wheelchair Travel Pass

Information and Application Form

Information

Introduction

The Scooter and Wheelchair Travel Pass is for people with a permanent and severe disability (being for the term of their life and not expected to improve) who depend on the use of a scooter or wheelchair for mobility outside of their home.

The information included in this form is intended to assist the applicant and their General Practitioner or Specialist in understanding eligibility for the Scooter and Wheelchair Travel Pass.

The following is included in this form:

- Scooter and Wheelchair Travel Pass information.
- Scooter and Wheelchair Travel Pass Application Form.

What is the Scooter and Wheelchair Travel Pass?

It is a free travel pass for people in scooters or wheelchairs using public transport.

Who is the Scooter and Wheelchair Travel Pass for?

The Scooter and Wheelchair Travel Pass is for people with a permanent and severe disability (being for the term of their life and not expected to improve), who travel on Victoria's public transport network and depend on the use of a scooter or wheelchair for mobility outside of their home.

The Scooter and Wheelchair Travel Pass is for permanent Victorian residents only.

The Scooter and Wheelchair Travel Pass will only be issued to individuals who meet the eligibility criteria outlined in the application form.

Why has the Scooter and Wheelchair Travel Pass been introduced?

The Scooter and Wheelchair Travel Pass has been introduced to support independent travel for people who are dependent on scooters or wheelchairs.

The Scooter and Wheelchair Travel Pass is linked to progress by the Victorian Government in implementing the *Disability Discrimination Act 1992* and the Disability Standards for Accessible Public Transport 2002.

The Scooter and Wheelchair Travel Pass maybe withdrawn or altered at anytime.

Please note:

- The Victorian Government acknowledges that in some instances applicants may hold both a Multi Purpose Taxi Program card and a Scooter and Wheelchair Travel Pass.
- For your reference we have included the Disability Standards for Accessible Public Transport 2002 for Scooter and Wheelchairs (dimensions, stability or manoeuvrability) in Section 5 of this application form.
- If your application is approved and your scooter or wheelchair is outside of these standards, there is no guarantee that your scooter or wheelchair will be able to access all forms of public transport.

Who administers the Scooter and Wheelchair Travel Pass?

The Metlink Central Pass Office is responsible for issuing Victoria's public transport free travel passes, including the Scooter and Wheelchair Travel Pass.

How does the Scooter and Wheelchair Travel Pass work?

Like other free travel passes, the Scooter and Wheelchair Travel Pass is loaded onto a registered myki, that includes the pass holder's photograph and name printed on the card. The pass holder is required to carry the Scooter and Wheelchair Travel Pass with them at all times while travelling on Victoria's public transport network.

In line with other free travel passes, the Scooter and Wheelchair Travel Pass holder is required to touch on and touch off their travel pass on the myki ticketing system.

If the applicant is unable to touch on and touch off on the myki ticketing system, they may be eligible for the Access Travel Pass.

Where can I use the Scooter and Wheelchair Travel Pass?

The Scooter and Wheelchair Travel Pass entitles the pass holder to free travel on:

- Melbourne metropolitan trains, trams and buses
- V/Line services
- Urban bus services in regional cities
- Regional services that have a contract or service agreement with the Department of Transport

Free travel passes do not necessarily apply to CountryLink, Great Southern Railway, airport services, tourist railways, privately run bus services and chartered trains, trams and buses. Please check with the relevant operator before booking or travelling.

How do I apply for the Scooter and Wheelchair Travel Pass?

This application form must be completed by the applicant or, where the applicant is unable to complete and/or sign the form, by their guardian or agent. Information must also be provided by the applicant's General Practitioner or Specialist. Additional information from specialists may also be required.

Once completed the application form should be submitted to the Metlink Central Pass Office for processing.

All applications will be reviewed by the Scooter and Wheelchair Travel Pass Panel for eligibility. Where eligibility is unclear, additional information may be sought from the applicant and/or their General Practitioner or Specialist.

The Scooter and Wheelchair Travel Pass Panel and the Metlink Central Pass Office may also seek independent medical or specialist advice on particular applications. Any additional testing required by the Scooter and Wheelchair Travel Pass Panel and/or Metlink Central Pass Office will be undertaken at the applicant's expense.

What is the role of the Scooter and Wheelchair Travel Pass Panel?

The Department of Transport has established the Scooter and Wheelchair Travel Pass Panel to advise the Metlink Central Pass Office on the eligibility of the applicant and the information submitted.

How much does the Scooter and Wheelchair Travel Pass cost?

The Scooter and Wheelchair Travel Pass is issued free of charge by the Metlink Central Pass Office.

Replacement cards

The pass holder must advise the Metlink Central Pass Office as soon as possible if the Travel Pass is lost, stolen, non-operational or damaged, including if they become aware that the name or photograph is illegible. A free replacement Travel Pass will be issued.

Please note: A Statutory Declaration must be completed and submitted to the Metlink Central Pass Office for all lost or stolen Travel Passes.

Scooter and Wheelchair Travel Pass Application Form

How to apply

Step 1

Before completing the application form it is important that the applicant read and understand the information contained in this form, in particular:

Scooter and Wheelchair Travel Pass Information

- What is the Scooter and Wheelchair Travel Pass?
- Who is the Scooter and Wheelchair Travel Pass for?
- Why has the Scooter and Wheelchair Travel Pass been introduced?
- Who administers the Scooter and Wheelchair Travel Pass?
- How does the Scooter and Wheelchair Travel Pass work?
- Where can I use the Scooter and Wheelchair Travel Pass?
- How do I apply for the Scooter and Wheelchair Travel Pass?
- What is the role of the Scooter and Wheelchair Travel Pass Panel?

Disability Standards for Accessible Public Transport 2002 – Section 5 (page 17)

Scooter and Wheelchair Travel Pass Terms of Use – Section 6 (page 19)

Scooter and Wheelchair Travel Pass Privacy Notice – Section 7 (page 21)

Step 2

Applicant/Guardian/Agent to complete this application form.

Step 3

Obtain ONE (recent within 3 months) high quality, colour passport-size photograph (from a passport photo outlet).

Step 4

Have section 2 completed and signed by your General Practitioner or Specialist, if applicable.

Step 5

Have the reverse of the photograph signed by the same General Practitioner or Specialist who completed section 2.

If you are not required to complete section 2 of the application form, then the reverse of the photograph must be signed by a person who can witness statutory declarations.

A list of persons who can sign statutory declarations can be obtained on the website <http://www.justice.vic.gov.au/justices>.

Step 6

Applicant/Guardian/Agents need to read section 5 that outlines the Disability Standards for Accessible Public Transport 2002

Step 7

Return this application form to:

Metlink Central Pass Office

At Southern Cross Station located between Bourke and Little Bourke streets near the bus interchanges;

or mail to

Metlink Central Pass Office

Southern Cross Station

Mail Box 58

99 Spencer Street

DOCKLANDS VIC 3008

Please Note: Original applications and photographs cannot be returned under any circumstances.

Incomplete applications, including those without signatures or signed photographs, cannot be processed.

How to complete this form

Applicants

- All applicants are required to complete section 1 and section 3.
- All applicants are required to attach the signed photograph – section 4.

Guardian/Agents

- If you are completing and signing this application form on behalf of the applicant you are required to complete section 1, section 3 and section 4.

General Practitioner or Specialist

- The General Practitioner or Specialist is required to complete section 2 and sign the reverse of the photograph.

Please complete this application form in BLOCK LETTERS using blue or black pen.

Section 1: Applicant Information

The **Scooter and Wheelchair Travel Pass** will only be issued to the person whose details appear below. One application must be completed per applicant

1.1 Applicant's Details

Title: (please tick) Mr Mrs Miss Ms

Surname or family name: _____

First or given name: _____

Date of birth: _____ / _____ / _____ Male Female

Residential Address: _____

Suburb: _____

State: _____ Postcode: _____

Postal Address: _____

Suburb: _____

State: _____ Postcode: _____

Telephone – home: _____

Telephone – mobile: _____

Email (if available): _____

1.2 Are you a permanent resident of Victoria?

Yes No

1.3 Have you previously applied for the Scooter and Wheelchair Travel Pass?

Yes No

1.4 Why are you applying for the Scooter and Wheelchair Travel Pass?

1.5 Do you have a Multi Purpose Taxi Program (MPTP) card?

Yes: please complete your MPTP number below:

9	0	3	6	0	0	3	2	3										
---	---	---	---	---	---	---	---	---	--	--	--	--	--	--	--	--	--	--

If you answered **Yes**, proceed to question 1.6

No: please complete :

- Section 2 General Practitioner /Specialist Declaration*
- Section 3 Applicant/Guardian/Agent Declaration and
- Section 4 Photograph, of the application form.

1.6 If you answered Yes to question 1.5, please advise:

When you applied for the Multi Purpose Taxi Program (MPTP) did a General Practitioner or Specialist certify for the Multi Purpose Taxi Program (MPTP) that you are **dependent on a wheelchair** for mobility outside the home:

Yes: please complete:

- Section 3 Applicant/Guardian/Agent Declaration and
- Section 4 Photograph, ensuring a justice of the peace signs the back of your passport photograph.

No: please complete:

- Section 2 General Practitioner /Specialist Declaration,*
- Section 3 Applicant/Guardian/Agent Declaration and
- Section 4 Photograph, of the application form.

* **Please Note:** For those applicants completing Section 2, please bring your passport photograph with you to your General Practitioner or Specialist, as they must sign the reverse of your photograph.

Section 2: General Practitioner or Specialist's Declaration

Please ensure that all sections are completed to prevent the application being returned to you and delaying the processing of the application. Your complete answers to questions are critical in the assessment of the applicant's eligibility.

Assessment

2.1 Does the applicant permanently (being for the term of their life and not expected to improve) depend on the use of a wheelchair for mobility outside their home, due to their disability?

Yes

No

Or

2.2 Does the applicant permanently (being for the term of their life and not expected to improve) depend on the use of a scooter for mobility outside their home, due to their disability?

Yes

No

2.3 Please provide comment below if there is any further relevant information you would like to add.

2.4 Please indicate in what capacity you have made this assessment.

General Practitioner

Specialist

Please note: Remember to sign the back of the applicants passport photograph, certifying it is a true likeness of the applicants (state their full name).

2.5 My signature which appears on the next page confirms all of the following:

- I have read all the information provided by the applicant on this form and verify that it is correct to the best of my knowledge.
- I am not the applicant or an immediate family member of the applicant.
- I agree to offer all reasonable information to assist the Scooter and Wheelchair Travel Pass Panel to determine the applicant's eligibility.
- I have signed the reverse of the applicant's photograph and confirm it is a true likeness of the applicant.

2.6 General Practitioner or Specialist Details

Name: _____

Employer/Business Name: _____

Business Address: _____

Suburb: _____

State: _____ Postcode: _____

Business Telephone number: _____

Signature:

Date: ____ / ____ / ____

Australian Health Practitioner Regulation Agency
(AHPRA):

AHPRA Registration Number:

□	□	□	□	□	□	□	□	□	□	□	□	□	□
---	---	---	---	---	---	---	---	---	---	---	---	---	---

Professional Stamp:

Section 3: Applicant/Guardian/Agent Declaration

3.1 I confirm that the signature on the next page verifies the following:

- ✓ I have a permanent and severe disability (being for the term of my life and that is not expected to improve) which means that I am required to use a scooter or wheelchair for mobility outside my home.
- ✓ I authorise Public Transport Authorities[#] to verify the information contained in this form, and to obtain and disclose any information relating to this application for the purpose of assessing my eligibility for a Scooter and Wheelchair Travel Pass. This may include obtaining information held by government departments and agencies, and disclosing information contained in this form or obtained in connection with this application for the purpose of assessing eligibility.
- ✓ I agree that the General Practitioner or Specialist who completed Section 2 of this application may disclose information about me to the Metlink Central Pass Office or the Department of Transport to assist with the assessment of my application.
- ✓ I declare that the information in this application is correct.
- ✓ I have read and acknowledge the Disability Standards for Accessible Public Transport 2002 – Section 5.
- ✓ I accept the Scooter and Wheelchair Travel Pass Terms of Use – Section 6.
- ✓ I have read the Scooter and Wheelchair Travel Pass Privacy Notice – Section 7.

3.2 Please provide the following signatures:

Applicant Signature (must be 18 years and over):

OR

Guardian/Agent Signature for applicants unable to sign
(must be 18 years and over)

Signature:

Date: _____ / _____ / _____

3.3 Guardian/Agent Details

Guardian/Agent Name (and relationship to the applicant):

Guardian/Agent Telephone:

Section 4: Photograph

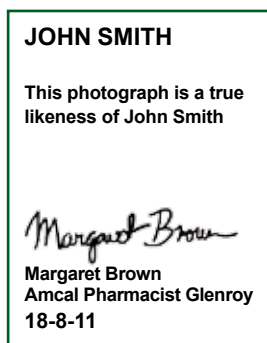

(Example on reverse side)

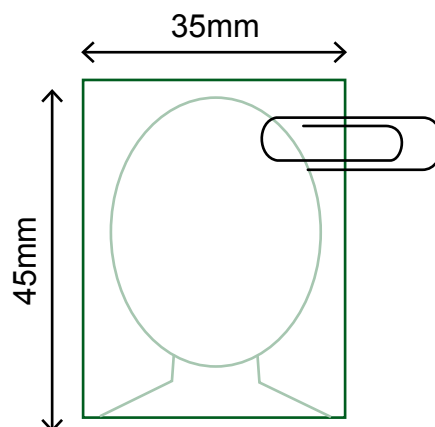

(Passport-size photograph)

A photograph is **MANDATORY** for ALL applicants.

Affix **ONE** recent (within 3 months) high quality colour passport-size photograph to the form.

The colour passport-size photograph:

- must be a clear head shot taken front on
- must have your full name printed on the reverse of the photograph and signed by the same General Practitioner or Specialist who signed section 2, or by a person who can witness statutory declarations (if you were not required to complete section 2). See example above

Please Note:

- A list of persons who can sign statutory declarations can be obtained on the website <http://www.justice.vic.gov.au/justices>.
- Photocopies of photographs or black and white photographs will not be accepted.
- The photograph is kept on file to make it easier for you to get a replacement scooter and wheelchair travel pass in the event it is lost, stolen or becomes non-operational.

Section 5: Disability Standards for Accessible Public Transport 2002 – Scooter or Wheelchair Size

The Disability Standards for Accessible Public Transport 2002 are listed below and detail the specifications for public transport in relation to its capacity to accommodate scooters and wheelchairs.

Please note, if your application is approved and your scooter or wheelchair cannot be accommodated within these standards, there is no guarantee that your scooter or wheelchair will be able to access all forms of public transport.

Dimensions

The mobility aid needs to:

- fit within an allocated space of 1300 mm by 800 mm
- be no more than 750 mm wide at a height 300 mm above the ground to fit between the wheel axles of a bus.

The total weight of the passenger, the assistant and the mobility aid needs to be less than 300 kg. This is to ensure the total weight does not exceed the maximum capacity of a boarding device (for example, ramp) which is 300 kg.

Stability

The mobility aid needs to:

- be able to move in the direction determined by the transport operator
- have effective braking systems to maintain stability.

Manoeuvrability

The mobility aid should be able to:

- turn 180 degrees within an area 2070 mm by 1540 mm
- cross a horizontal gap up to 40 mm wide
- mount a vertical rise (bump) up to 12 mm
- cross grating gaps up to 13 mm wide and 150 mm long
- negotiate a 1:14 grade unassisted (for example, ramp)
- negotiate up to a 1:8 grade where the ramp is less than 1520 mm
- negotiate a 1:4 grade with assistance (for example, ramp).

Section 6: Terms of Use

1. The Travel Pass entitles the pass holder to free travel on Victoria's public transport network. As at the date of issue of these terms of use, this means:
 - Melbourne metropolitan trains, trams and buses
 - V/Line services
 - Urban bus services in regional cities
 - Regional services that have a contract or service agreement with the Department of Transport

Free travel passes do not necessarily apply to CountryLink, Great Southern Railway, airport services, tourist railways, privately run bus services and chartered trains, trams and buses. Please check with the relevant operator before booking or travelling.

2. The pass holder will be issued with a registered myki and will have their photograph and name printed on the card.
3. Only the person whose photograph and details appear on the Travel Pass is permitted to use the pass.
4. The pass holder must carry their Travel Pass at all times when travelling on Victoria's public transport network.
5. The Travel Pass remains the property of the Transport Ticketing Authority (TTA). Representatives of Public Transport Authorities[#] may inspect, deactivate, suspend, hotlist or take possession of the Travel Pass or require its return at any time if the pass holder is in breach of the terms of use.

6. TTA may change these terms of use from time to time. The current version of the terms of use may be obtained by calling the Metlink Central Pass Office on 9619 1159. Where TTA reasonably considers that any such change will have more than a minor detrimental effect on Travel Pass holders generally, the change will be notified by the Metlink Central Pass Office to pass holders in advance in writing.
7. The pass holder must not alter, tamper, or interfere with the Travel Pass.
8. The pass holder agrees to advise the Metlink Central Pass Office as soon as possible if the Travel Pass is lost, stolen, damaged or non-operational, including if they become aware that the name or photograph is illegible.
9. A free replacement Travel Pass will be issued for all lost, stolen, damaged and non-operational Travel Passes.

Please note: A Statutory Declaration must be completed and submitted to the Metlink Central Pass Office for all lost or stolen Travel Passes.

Section 7: Privacy Notice

You will generally be able to access your personal information. If personal information sought by Transport Ticketing Authority ('TTA') is not provided, TTA may not be able to provide the myki. For further information about privacy and on rights of access to personal information, visit myki.com.au or call 13 6954 (13 myki).

Personal information provided by or about you or generated by using the myki is collected by Public Transport Authorities[#] to issue and administer the myki and relevant entitlements. Personal information held by Public Transport Authorities[#] may be used or disclosed (including to each other) for the operation of myki; for ticketing enforcement; in emergencies; otherwise as required by or under law; or with your consent. Public Transport Authorities[#] may send you information about transport-related services.

"Public Transport Authorities" means TTA, the Department of Transport and any agent, contractor or delegate of TTA and the Department of Transport including Metlink and public transport operators.

Section 8: Contacts for further information

For all Scooter and Wheelchair Travel Pass enquires you can contact the following services for assistance:

Metlink Central Pass Office

Telephone: (03) 9619 1159

Visit Staff: At Southern Cross Station located between Bourke and Little Bourke streets near the bus interchanges

Website: www.metlinkmelbourne.com.au

TTY: (03) 9619 2727

National Relay Service: 13 36 77

Speech-to-Speech Relay Service: 1300 555 727

Multilingual information

For all Scooter and Wheelchair Travel Pass telephone enquiries in languages other than English, please use the following phone numbers:

Arabic	9321 5440	Mandarin	9321 5454
Cantonese	9321 5441	Somali	9321 5446
Croatian	9321 5442	Spanish	9321 5447
Dinka	9321 5452	Sudanese	9321 5453
Greek	9321 5443	Turkish	9321 5448
Italian	9321 5444	Vietnamese	9321 5449
Macedonian	9321 5445		

All other foreign languages 9321 5450

Office Use Only

Metlink Central Pass Office (CPO)

CPO application number:

<input type="text"/>	<input type="text"/>	<input type="text"/>	<input type="text"/>	<input type="text"/>	<input type="text"/>	<input type="text"/>	<input type="text"/>	<input type="text"/>	<input type="text"/>	<input type="text"/>	<input type="text"/>	<input type="text"/>	<input type="text"/>	<input type="text"/>
----------------------	----------------------	----------------------	----------------------	----------------------	----------------------	----------------------	----------------------	----------------------	----------------------	----------------------	----------------------	----------------------	----------------------	----------------------

Date received from applicant: _____ / _____ / _____

Checked by – Initials: _____

Date forwarded to Scooter and Wheelchair

Travel Pass Panel: (SWTPP): _____ / _____ / _____

Date received recommendation from SWTPP: _____ / _____ / _____

Scooter and Wheelchair Travel Pass card number:

3	0	8	4	2	5	<input type="text"/>	<input type="text"/>	<input type="text"/>	<input type="text"/>	<input type="text"/>	<input type="text"/>	<input type="text"/>	<input type="text"/>	<input type="text"/>
---	---	---	---	---	---	----------------------	----------------------	----------------------	----------------------	----------------------	----------------------	----------------------	----------------------	----------------------

Date Applicant advised of recommendation: _____ / _____ / _____

Date Travel Pass issued: _____ / _____ / _____

Scooter and Wheelchair Travel Pass Panel

Date received from CPO: _____ / _____ / _____

Date recommendation sent to CPO: _____ / _____ / _____

Recommendation:

Approved Declined

Comments: _____

Initials _____

Date: _____ / _____ / _____